

## 1 Scope:

- 1.1 This specification is applicable to FTH series fully lead-free and halogen-free High power Low-Resistance thick film chip resistors.
- 1.2 Fully lead-free products-No RoHs exemptions.
- 1.3 The product is for general electronic purpose.

## 2 Explanation Of Part Numbers:

(EX)

	<b>FTH</b>	<b>1206</b>	<b>T</b>	<b>R200</b>	<b>F</b>
Type	Size	Packaging	Nominal Resistance		Resistance Tolerance
Fully lead-free High power Low-Resistance Thick Film Chip Resistors	0805	T : Taping	3-Digit	5% $0.1\Omega \leq R < 1\Omega$ EX. $0.1\Omega = R10$	F = ± 1% J = ± 5%
	1206		4-Digit	5% $R < 0.1\Omega$ EX. $0.036\Omega = R036$	
1210	1% EX. $0.2\Omega = R200$				
2010	2512				

## 3 General Specifications:

Type	Rated Power at 70°C	Max. Rated Current	Max. Overload Current	T.C.R ( ppm / °C )	Resistance Range
					F(±1%)、J(±5%) E-24、E-96
FTH0805	$\frac{1}{4}$ W	5A	12.5A	±1500	$10m\Omega \leq R < 19m\Omega$
				±1200	$19m\Omega \leq R < 33m\Omega$
				±800	$33m\Omega \leq R < 50m\Omega$
				±600	$50m\Omega \leq R < 100m\Omega$
				±200	$100m\Omega \leq R < 1000m\Omega$
FTH1206	$\frac{1}{2}$ W	7.07A	17.68A	±1500	$10m\Omega \leq R < 19m\Omega$
				±1200	$19m\Omega \leq R < 25m\Omega$
				±1000	$25m\Omega \leq R < 50m\Omega$
				±600	$50m\Omega \leq R < 100m\Omega$
				±200	$100m\Omega \leq R < 1000m\Omega$
FTH1210	$\frac{3}{4}$ W	8.66A	21.65A	±1500	$10m\Omega \leq R < 19m\Omega$
				±1000	$19m\Omega \leq R < 25m\Omega$
				±700	$25m\Omega \leq R < 50m\Omega$
				±400	$50m\Omega \leq R < 100m\Omega$
				±200	$100m\Omega \leq R < 1000m\Omega$
FTH2010	1W	4.47A	11.18A	±200	$50m\Omega \leq R < 150m\Omega$
				±100	$150m\Omega \leq R < 1000m\Omega$
FTH2512	1.5W	5.48A	13.69A	±200	$50m\Omega \leq R < 150m\Omega$
				±100	$150m\Omega \leq R < 1000m\Omega$
Operating Temperature Range				-55°C ~ +155°C	

### 3.1 Power Derating Curve:

Temperature Range:  $-55^{\circ}\text{C} \sim +155^{\circ}\text{C}$

If the ambient temperature exceeds 70 degrees centigrade to 155 degrees centigrade, the power can be modified by the curve as below.

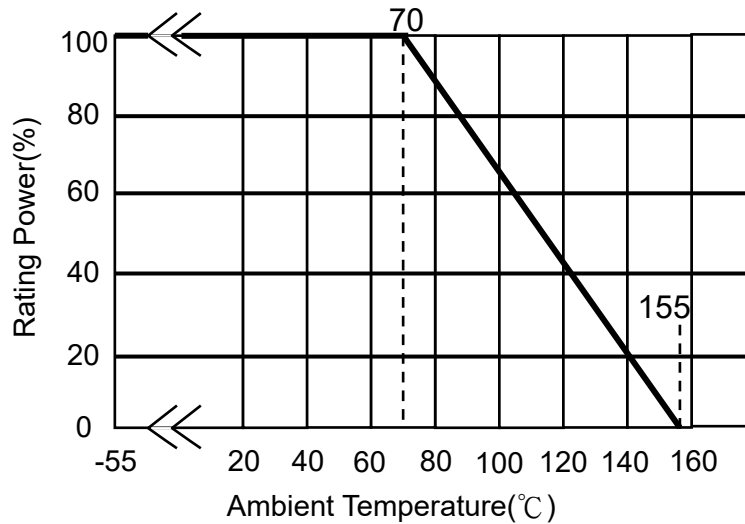

### 3.2 Current Rating

Rated Current: The resistor shall have a DC continuous working current or a rms. AC continuous working current at commercial-line frequency and wave form corresponding to the power rating, as determined from the following:

$$I = \sqrt{P/R}$$

$I$  = Rated current (A)  
 $P$  = Power rating (w)  
 $R$  = Nominal resistance( $\Omega$ )

## 4 Dimensions:

Unit:mm

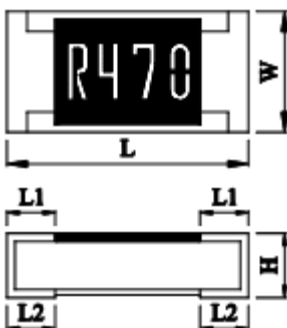

Dimension		L	W	H	L1	L2
Type	Size Code					
FTH	0805	2.00±0.10	1.25±0.10	0.50±0.10	0.35±0.20	0.35±0.20
FTH	1206	3.05±0.10	1.55±0.10	0.50±0.10	0.45±0.20	0.65±0.15
FTH	1210	3.05±0.10	2.55±0.10	0.55±0.10	0.50±0.20	0.50±0.20
FTH	2010	4.95±0.10	2.45±0.10	0.70±0.10	0.65±0.20	0.70±0.20
FTH	2512	6.40±0.20	3.20±0.20	0.70±0.10	0.72±0.20	0.69±0.20

## 5 Structure Graph:

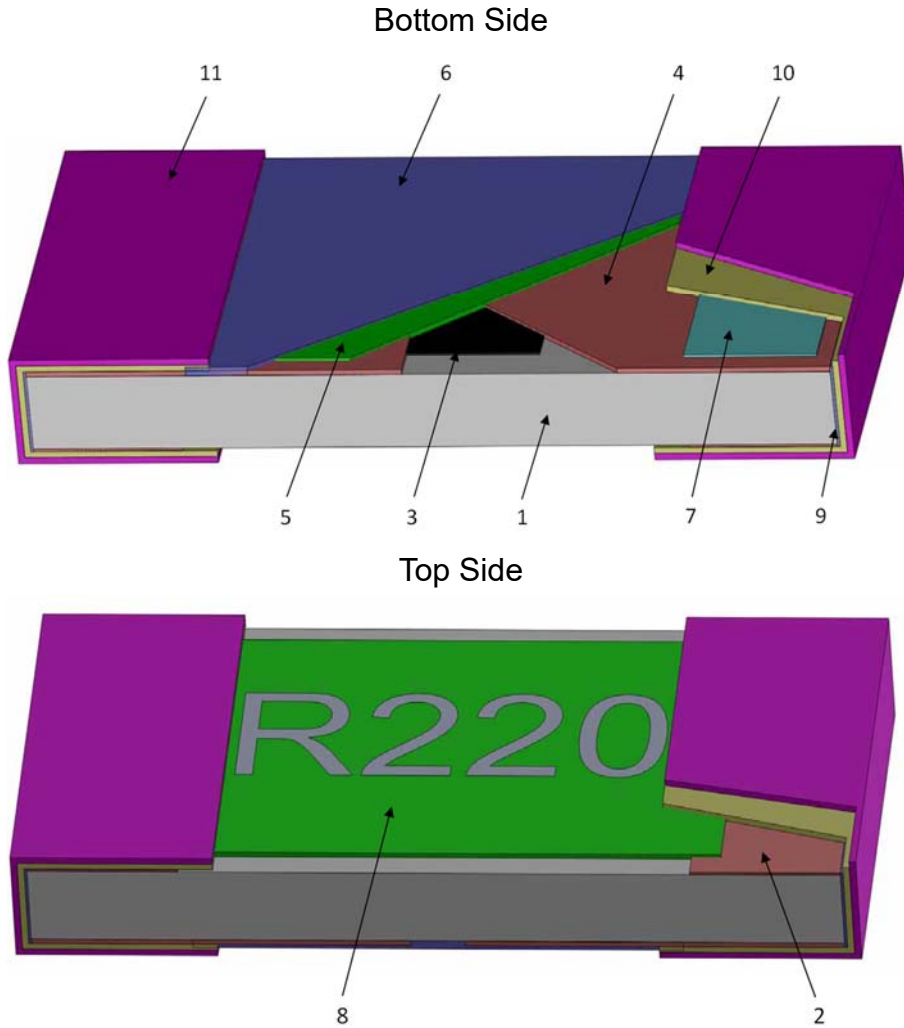

1	Ceramic substrate	7	2nd Bottom inner electrode
2	1st Top inner electrode	8	G2 layer + Marking
3	Resistive layer	9	Terminal inner electrode
4	Bottom inner electrode	10	Ni plating
5	1st Protective coating	11	Sn plating
6	2nd Protective coating		

## 6 Reliability Test:

### 6.1 Electrical Performance Test

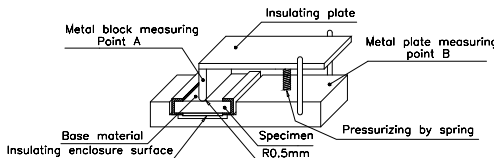
Item	Conditions	Specifications
		Resistors
Temperature Coefficient of Resistance	$TCR(ppm/^{\circ}C) = \frac{(R2-R1)}{R1(T2-T1)} \times 10^6$ <p>R1: Resistance at room temperature            R2: Resistance at -55°C or +125°C            T1: Room temperature            T2: Temperature -55°C or +125°C</p> <p>Refer to JIS-C5201-1 4.8</p>	Refer to item 3. general specifications
Short Time Overload	<p>Applied 2.5 times rated voltage for 5 seconds and release the load for about 30 minutes , then measure its resistance variance rate.(Rated voltage refer to item 3. general specifications)</p> <p>Refer to JIS-C5201-1 4.13</p>	$\Delta R\% = \pm 2.0\%$
Insulation Resistance	<p>Put the resistor in the fixture, add 100 VDC in + , - terminal for 60 sec then measured the insulation resistance between electrodes and insulating enclosure or between electrodes and base material.            Refer to JIS-C5201-1 4.6</p> 	$\geq 10^9 \Omega$
Dielectric Withstand Voltage	<p>Put the resistor in the fixture, add VAC (see spec. below) in +, - terminal for.            FTH0805 、 1206 、 1210 、 2010 、 2512 apply 500 VAC 1 minute.</p> <p>Refer to JIS-C5201-1 4.7</p>	No short or burned on the appearance.

## 6.2 Mechanical Performance Test

Item	Conditions	Specifications
		Resistors
Terminal Strength	<p>Test1: The resistor mounted on the board, then applied 5N pushing force on the sample rear for 10sec.</p> <p>Test2: The resistor mounted on the board and slowly add force on the sample rear until the sample termination is breakdown.</p> <p>Refer to JIS-C5201-1 4.16</p>	<p>Test1: No evidence of mechanical damage</p> <p>Test2: <math>F \geq 5N</math></p>
Resistance to Solvent	<p>The tested resistor be immersed into isopropyl alcohol of 20~25°C for 5±0.5 minutes, then the resistor is left in the room for 48 hrs, and measured its resistance variance rate.</p> <p>Refer to JIS-C5201-1 4.29</p>	<p><math>\Delta R\% = \pm 2.0\%</math></p>
Solderability	<p>Preconditioning: Put the tested resistor in the apparatus of PCT, at a temperature of 105°C, humidity of 100% RH, and pressure of <math>1.22 \times 10^5</math> Pa for a duration of 4 hours. Then after left the tested resistor in room temperature for 2 hours or more.</p> <p>Test method: The resistor be immersed into solder pot in temperature 235±3°C for 2±0.5 sec, then the resistor is left as placed under microscope to observed its solder area.</p> <p>Refer to JIS-C5201-1 4.17</p>	<p>Solder coverage over 95%</p>
Resistance to Soldering Heat	<p>☉Test method 1 (solder pot test): The tested resistor be immersed into molten solder of 260+5/-0°C for 10+1/-0 seconds. Then the resistor is left in the room for 1 hour.</p> <p>☉Test method 2 (solder pot test): The tested resistor be immersed into molten solder of 260+5/-0°C for 30+1/-0 seconds. Then the resistor is left as placed under microscope to observe its solder area.</p> <p>☉Test method 3 (Electric iron test): Preheating temperature : 350±10°C Electric iron preheating time : 3+1/-0 sec Preheating the electric iron on electrode termination, as after that step placed the iron over 60 min. and measured its resistance variance rate.</p> <p>Refer to JIS-C5201-1 4.18</p>	<p>Test item 1: (1). Variance rate on resistance <math>\Delta R\% = \pm 2.0\%</math></p> <p>Test item 2: (1). Solder coverage over 95%. (2). The underlying material (such as ceramic) shall not be visible at the crest corner area of the electrode.</p> <p>Test item 3: (1). Variance rate on resistance <math>\Delta R\% = \pm 2.0\%</math></p>

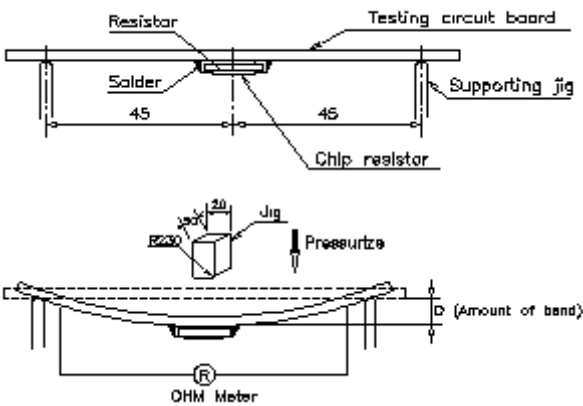
Item	Conditions	Specifications
Joint Strength of Solder	<p>◎Bending Strength: Solder tested resistor on to PC board. Add force in the middle down, and under load measured its resistance variance rate. D:FTH05=5mm FTH1206、1210=3mm FTH2010、2512=2mm</p> 	<p><math>\Delta R\% = \pm 2.0\%</math></p>
	Refer to JIS-C5201-1 4.33	

## 6.3 Environmental Test

Item	Conditions	Specifications								
		Resistors								
Resistance to Dry Heat	Put tested resistor in chamber under temperature $155\pm 5^{\circ}\text{C}$ for 1000 +48/-0 hours. Then leaving the tested resistor in room temperature for 60 minutes, and measure its resistance variance rate.  Refer to JIS-C5201-1 4.25	$\Delta R\% = \pm 2.0\%$								
Thermal Shock	Put chip resistors in the thermal shock machine ,and the temperature was $-55^{\circ}\text{C}$ for 15 minutes and $+125^{\circ}\text{C}$ for 15 minutes, the total of 300 times and then removed, let stand for more than 1 hour before measuring the resistance change rate... <table border="1" style="margin-left: 20px;"> <thead> <tr> <th colspan="2">Testing Condition</th> </tr> </thead> <tbody> <tr> <td>Lowest Temperature</td> <td><math>-55\pm 5^{\circ}\text{C}</math></td> </tr> <tr> <td>Highest Temperature</td> <td><math>125\pm 5^{\circ}\text{C}</math></td> </tr> <tr> <td>Temperature-retaining time</td> <td>15 minutes each</td> </tr> </tbody> </table> Refer to MIL-STD 202 Method 107	Testing Condition		Lowest Temperature	$-55\pm 5^{\circ}\text{C}$	Highest Temperature	$125\pm 5^{\circ}\text{C}$	Temperature-retaining time	15 minutes each	$\Delta R\% = \pm 2.0\%$
Testing Condition										
Lowest Temperature	$-55\pm 5^{\circ}\text{C}$									
Highest Temperature	$125\pm 5^{\circ}\text{C}$									
Temperature-retaining time	15 minutes each									
Loading Life in Moisture	Put the tested resistor in the chamber under temperature $40\pm 2^{\circ}\text{C}$ , relative humidity 90~95% and load the rated voltage for 90 minutes on, 30 minutes off, total 1000 hours. Then leaving the tested resistor in room temperature for 60 minutes, and measure its resistance variance rate.  Refer to JIS-C5201-1 4.24	$\Delta R\% = \pm 3.0\%$								
Load Life	Put the tested resistor in chamber under temperature $70\pm 2^{\circ}\text{C}$ and load the rated voltage for 90 minutes on, 30 minutes off, total 1000 hours. Then leaving the tested resistor in room temperature for 60 minutes, and measure its resistance variance rate.  Refer to JIS-C5201-1 4.25	$\Delta R\% = \pm 3.0\%$								

## 7 Measurement Point :

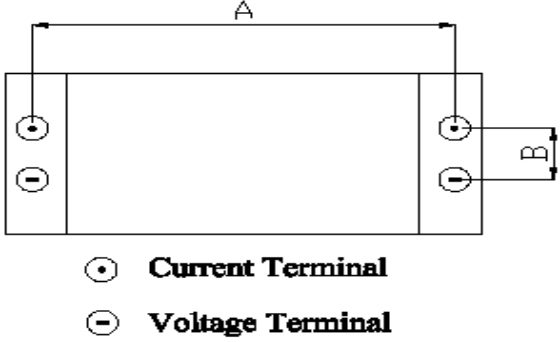
Bottom electrode	Unit : mm		
 <p style="text-align: center;"> <span style="display: inline-block; width: 10px; height: 10px; border: 1px solid black; border-radius: 50%; margin-right: 5px;"></span> <b>Current Terminal</b>  <span style="display: inline-block; width: 10px; height: 10px; border: 1px solid black; border-radius: 50%; margin-right: 5px; vertical-align: middle;"></span> <b>Voltage Terminal</b> </p>	DIM	A	B
TYPE			
FTH0805		1.80±0.05	0.35±0.05
FTH1206		2.90±0.05	0.35±0.05
FTH1210		2.90±0.05	0.35±0.05
FTH2010		4.50±0.05	1.15±0.05
FTH2512		5.90±0.05	1.60±0.05

## 8 Plating Thickness :

- 8.1 Ni:  $\geq 2\mu\text{m}$
- 8.2 Sn(Tin):  $\geq 3\mu\text{m}$
- 8.3 Sn(Tin): Matte Sn

## 9 Rule of package empty quantity:

- 9.1 Empty quantity for each reels not allowed to exceed 0.1% of the whole quantity, and continuous 2pcs (included) empty are also unallowed.



## 10 Technical application notes:(This is a recommend dation, please adjust it according to actual application)

### 10.1 Recommend Soldering Method:

#### 10.1.1Lead Free IR Reflow Soldering Profile(MEET J-STD-020D)

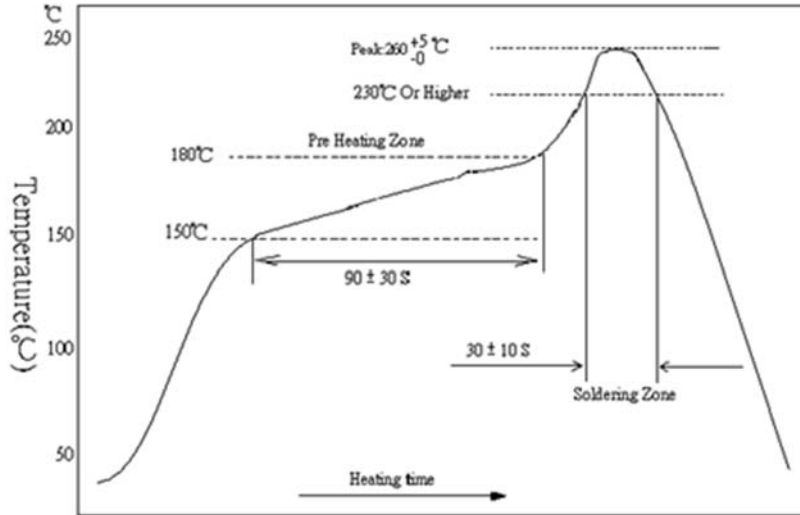

Remark: The peak temperature of soldering heat is  $260^{+5}_{-0}$  °C for 10 seconds

#### 10.1.2Lead Free Double-Wave Soldering Profile

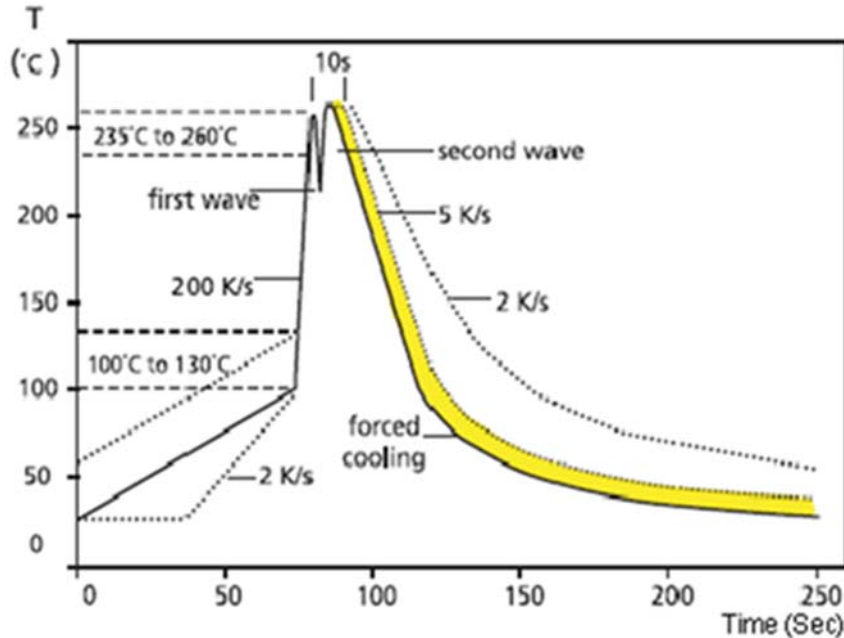

10.1.3Soldering Iron: temperature  $350^{\circ}\text{C} \pm 10^{\circ}\text{C}$ , dwell time shall be less than 3 sec.

## 10.2 Land Pattern Design (For Reflow Soldering) :

When a component is soldered, the resistance after soldering changes slightly depending on the size of the soldering area and the amount of soldering. When designing a circuit, it is necessary to consider the effect of a decrease or increase in its resistance.

Unit:mm

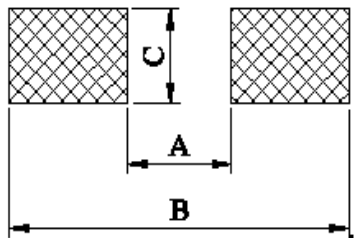

TYPE \ DIM	A	B	C
<b>FTH0805</b>	1.2	3.0	1.3
<b>FTH1206</b>	2.2	4.2	1.6
<b>FTH1210</b>	2.2	4.2	2.8
<b>FTH2010</b>	3.5	6.1	2.8
<b>FTH2512</b>	3.8	8.0	3.5

## 10.3 Environment Precautions:

This specification product is for general electronic use, ABCO will not be responsible for any damage, cost or loss caused by using this specification product in any special environment. If other applications, you need to confirm with ABCO.

If consumer intends to use our Company product in special environment or condition (including but not limited to those mentioned below), then will need to make individual recognition of product features and reliability accordingly.

- (a)Used in high temperature and humidity environment.
- (b)Exposed to sea breeze or other corrosive gas, such as Cl<sub>2</sub>、H<sub>2</sub>S、NH<sub>3</sub>、SO<sub>2</sub> and NO<sub>2</sub>.
- (c)Used in non-verified liquids including water, oil, chemical and organic solvents.
- (d)Using non-verified resin or other coating material to seal or coat our Company product.
- (e)After soldering, it is necessary to use water-soluble detergents to clean residual solder fluxes, even though no-clean fluxes are recommended.

## 10.4 Momentary Overload Precautions:

The product might be out of function when momentary overloaded. Please make sure to avoid momentary overloading while using and preserving



**10.5 Operation and Processing Precautions:**

- (a) Avoid damage to the edge of resistor and protective layer caused by mechanical stress.
- (b) Handle with care when printing circuit board (PCB) is divided or fixed on support body, because bending of printing circuit board (PCB) mounting will make mechanical stress for resistors.
- (c) Make sure the power rating is under the limit when using the resistor. When power rating is over the limit, the resistor will be overloaded. There might be machinery damage due to the climbing temperature.
- (d) If the resistor will be exposed under massive impact load (shock wave) in a short period of time, the working environment must be set up well before use.
- (e) Please make evaluation and confirmation when the product is well used in your company and have a through consideration of it's fail-safe design to ensure the system safety.

**11 Stock period:**

- 11.1 The temperature condition must be controlled as  $25\pm 5^{\circ}\text{C}$ , the R.H. must be controlled as  $60\pm 15\%$ . The stock can maintain quality level in two years.
- 11.2 Please avoid the mentioned harsh environment below when storing to ensure product performance and its weldability. Places exposed to sea breeze or other corrosive gas, such as  $\text{Cl}_2$ 、 $\text{H}_2\text{S}$ 、 $\text{NH}_3$ 、 $\text{SO}_2$  and  $\text{NO}_2$ .
- 11.3 When the product is moved and stored, please ensure the correct orientation of the box. Do not drop or squeeze the box. Otherwise, the electrode or the body of the product may be damaged.

**12 The carton packaged for electronic-information products is made by the symbol as follows: (For China)**

	
Marking for control of pollution cause by electronic-information products	Marking for package recovery

## Legal disclaimer

ABCO, its distributors and agents (collectively, "ABCO"), hereby disclaims any and all liabilities for any errors, inaccuracies or incompleteness contained in any product related information, including but not limited to product specifications, datasheets, pictures and/or graphics. ABCO may make changes, modifications and/or improvements to product related information at any time and without notice.

ABCO makes no representation, warranty, and/or guarantee about the fitness of its products for any particular purpose or the continuing production of any of its products. To the maximum extent permitted by law, ABCO disclaims (i) any and all liability arising out of the application or use of any ABCO product, (ii) any and all liability, including without limitation special, consequential or incidental damages, and (iii) any and all implied warranties, including warranties of fitness for a particular purpose, non-infringement and merchantability.

ABCO defined this product is for general electrical use , not design for any application for automotive electrical ,life-saving or life support equipment, or any application which may inflict casualties if ABCO product failure occurred. When consumer is using or selling products of ABCO without having discussion with the sales representatives and specifically stated the applicability mentioned above in a written form, then the client need to take a full responsibility and agree to protect ABCO from punishment and damage.

Information provided here is intended to indicate product specifications only. ABCO reserves all the rights for revising this content without further notification, as long as products are unchanged. Any product change will be announced by ECN.